

# BF-SERIES COPYBOARD

**BF-030S / BF-041S / BF-035  
BF-030PC / BF-030W / BF-041W**

INSTALLATION MANUAL

## **PLUS Vision Corp.**

9610 SW SUNSHINE CT.  
SUITE 800  
BEAVERTON, OR 97005  
800-211-9001 • 503-748-8700



PLUS Vision Corp. has  
ISO 14001 certification.  
Certificate No. NQE-0210118A



PLUS Vision Corp. has  
ISO 9001 certification.  
Certificate No. 12 100 17398 TMS

©2001, PLUS Vision Corp.

428-707-01A

# PLUS







- To prevent electrical shock and insure safe wall mounting, please consult your authorized PLUS dealer on the copyboard assembling and wall mounting methods.

**Note:** The wall must be capable of holding an object weighing more than 1010N [103 kgf (about 227 lbs)] for BF-030S, BF-030PC, BF-041S or 1137N [116 kgf (about 256 lbs)] for BF-030W, BF-035, BF-041W.

**Note:** Use anchor set and screws suitable for the type of wall to which to copyboard will be mounted.  
 (\* The wall and its internal structure must be checked because they differ depending on the building.)

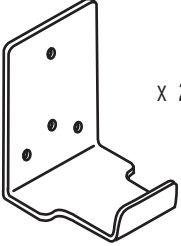
- The following parts are contained in the accessory box. Be sure to check them before starting installation work.

**[Accessories for Mounting to Wall]**

Plate	Upper bracket	Lower bracket
 x 2	 x 2	 x 2
Plate fitting screw	Plate/upper bracket fitting screw	Pipe frame cap
 x 4 M4x 15mm (19/32") Tap tight screw	 x 2 M6x 15mm (19/32")	 x 2

- Before installation: Prepare the anchor set and screws suitable for the type of wall.  
 (\* The wall and its internal structure must be checked because they differ depending on the building.)

## Checking Installation Position

- The mounting positions to the wall are shown below.
- For the mounting surface, select a flat wall surface.
- The installation height is optional, but an easy-to-use height should be set by checking the position of the top of the main body

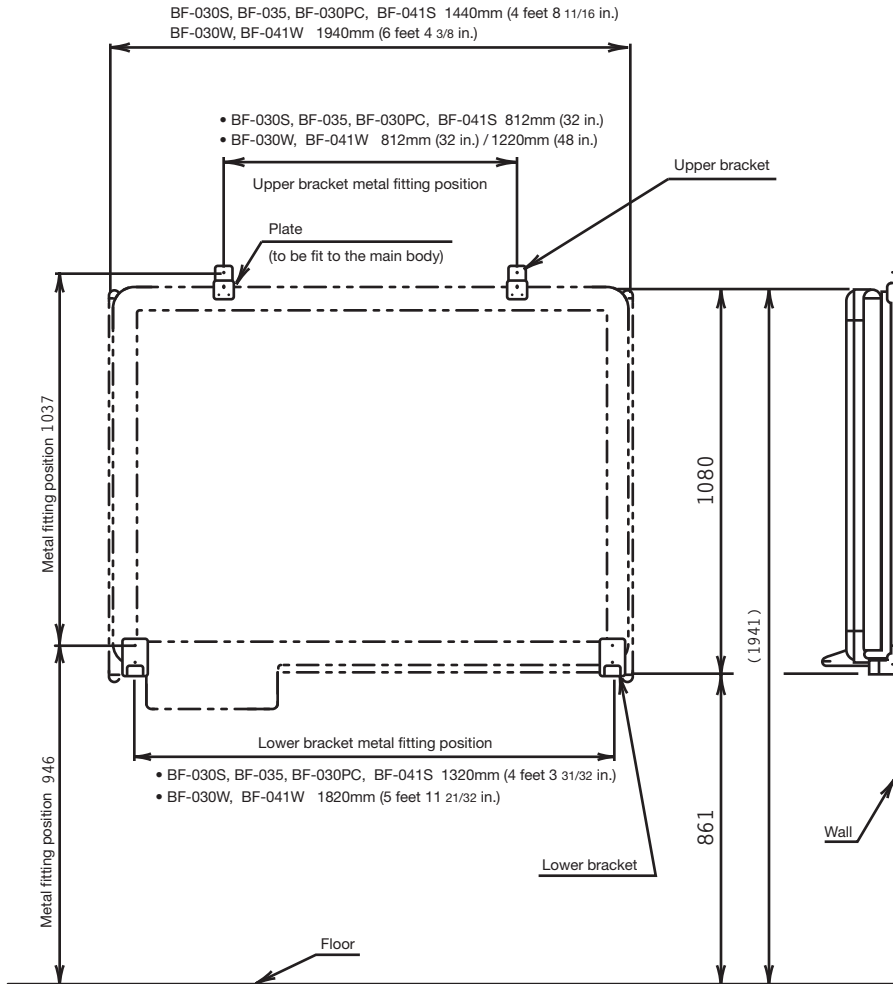

Fig. 1

## BF-Series Copyboard Wall Mounting Method

1. First, check that the wall can withstand the weight of the copyboard.

**Note:** The wall must be capable of holding an object weighing more than 1010N [103 kgf (about 227 lbs)] for BF-030S, BF-030PC, BF-041S or 1137N [116 kgf (about 256 lbs)] for BF-030W, BF-035, BF-041W.

**Note:** Use anchor set and screws suitable for the type of wall to which to copyboard will be mounted.  
 (\* The wall and its internal structure must be checked because they differ depending on the building.)

- The wall mounting surface must be flat and free from warp and strain.

2. Fit the lower brackets to the wall. (Fig. 2)

- The spacing between the lower bracket mounting holes of the wall is 1320 mm (4 feet 3 31/32 in.) for BF-030S, BF-030PC, BF-035, BF-041 or 1820 mm (5 feet 11 21/32 in.) for BF-030W, BF-041W.

- Fit the tow lower brackets at the same height. (See Fig.1)  
 (\* For the fitting position, be sure to check levelness with a level.)

**Note:** Use anchor set and screws suitable for the type of wall to which to copyboard will be mounted.  
 (\* The wall and its internal structure must be checked because they differ depending on the building.)

- For fitting the lower brackets, the screws must be firmly tightened.

**Important note:** The weight of the copyboard is 32 kg or more ([32kgf (70.5 lbs)] for BF-030S, BF-030PC, BF-041S or 36 kg or more [36 kgf (79.4 lbs)] for BF-030W, BF-035 and BF-041W. The installation must be made in accordance with this manual, otherwise injury or damage may occur.

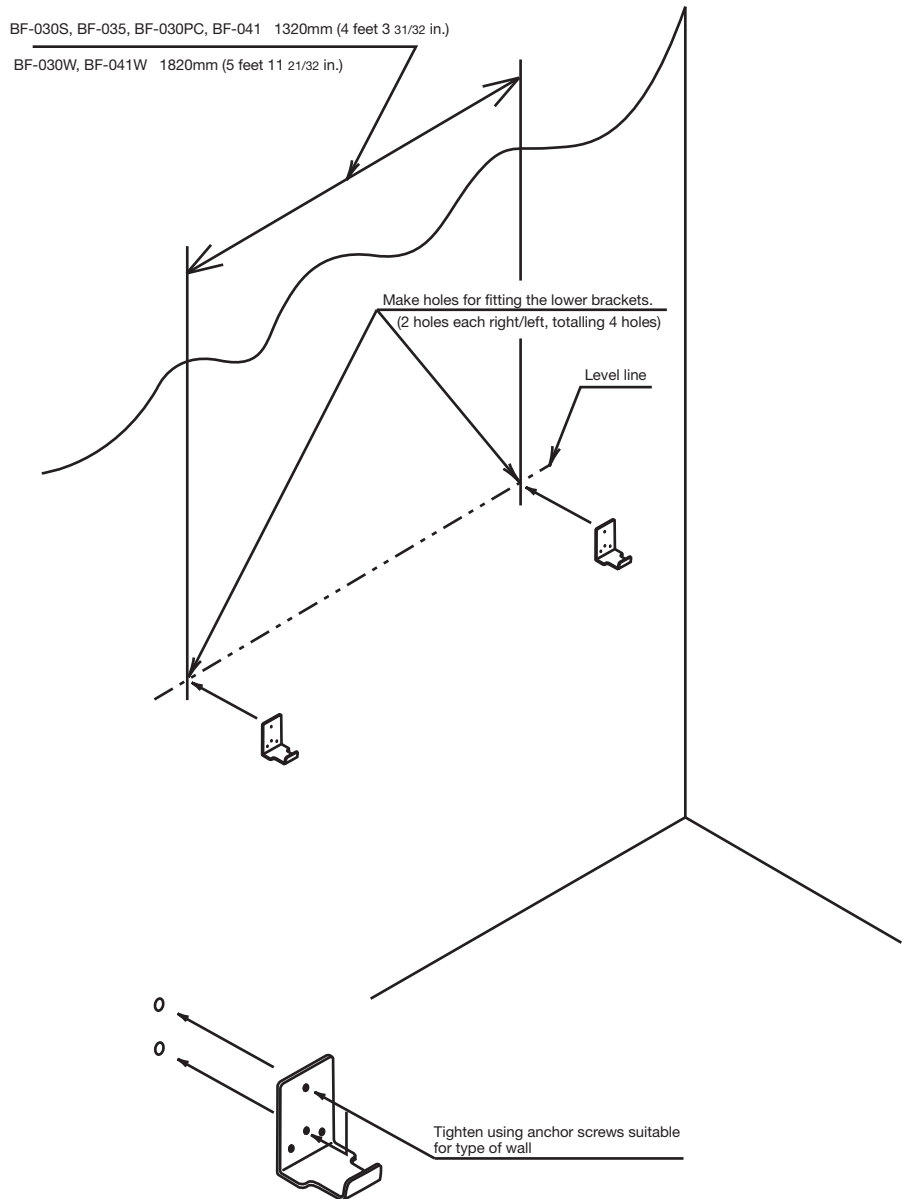

3. Fit the board plates to the copyboard.

- The spacing between the holes for fitting the board plates is 812 mm (32 in.) for BF-030, BF-030PC, BF-035, BF-041S or 812 mm (32 in.)/1220 mm (48 in.) for BF-030W and BF-041W).
- The screws for fitting the board plates to the copyboard must be firmly tightened. (Tightening torque 8 kgf or more)

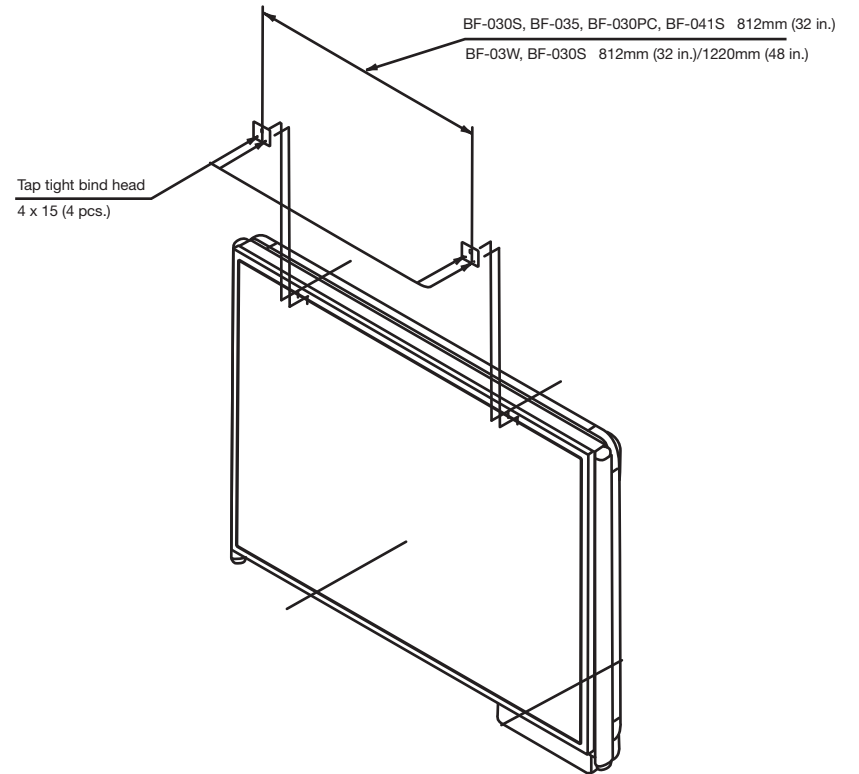

4. Fit the upper brackets to the board plate at the top of the copyboard.

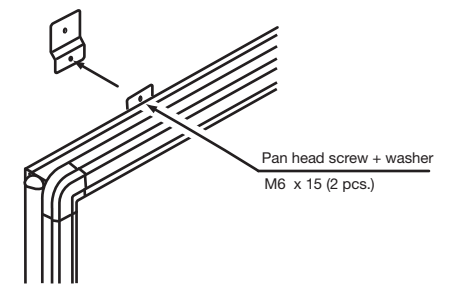

5. Mark the board plate fitting hole positions on the wall. (Fig. 5)

- Place the copyboard on the lower brackets.
- Mark the board plate fitting hole positions on the wall.
- Lower the copyboard, drill pilot holes for anchor screws at the board plate fitting hole positions marked on the wall, and install the anchor screws.

6. Place the copyboard on the lower brackets and fit the upper brackets to the wall. (Fig. 5)

- When the copyboard is installed do not press it strongly against the wall, etc. The fluorescent tub, etc. inside the copyboard may be damaged.

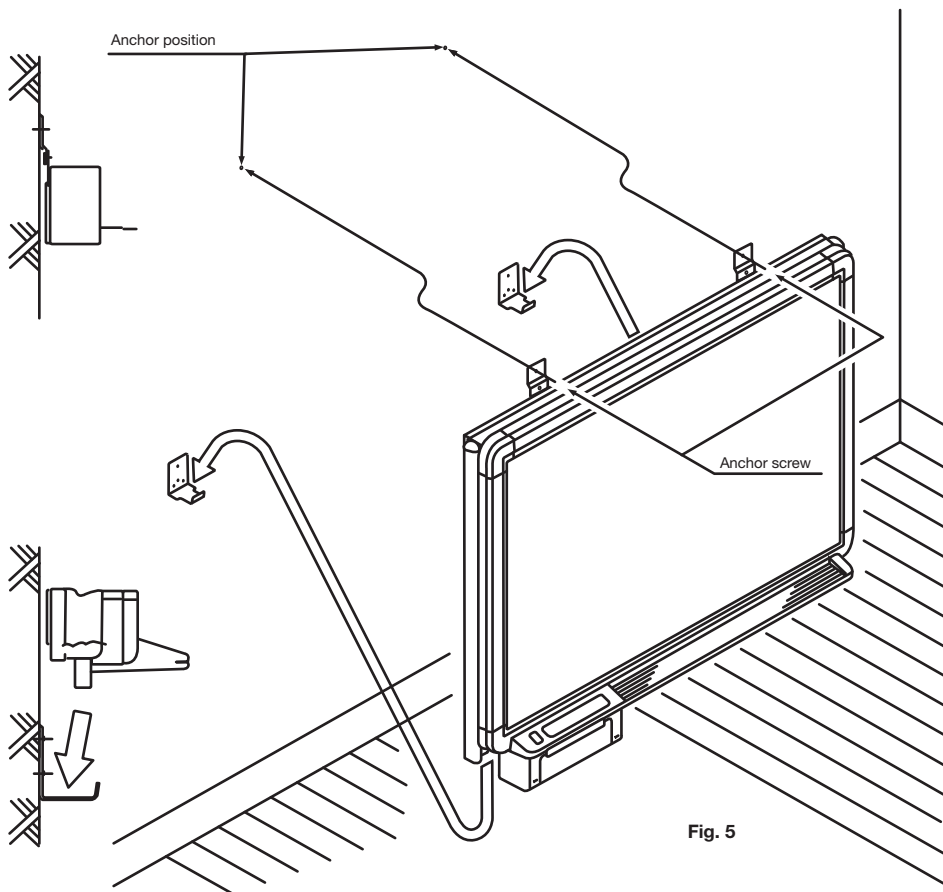

Fig. 5

7. Install the pipe cap at the right and left of the copyboard. (Fig. 6)

**Note:** After the copyboard is installed, check the integrity of the mounting by applying light force to the copyboard to confirm that is sufficiently mounted

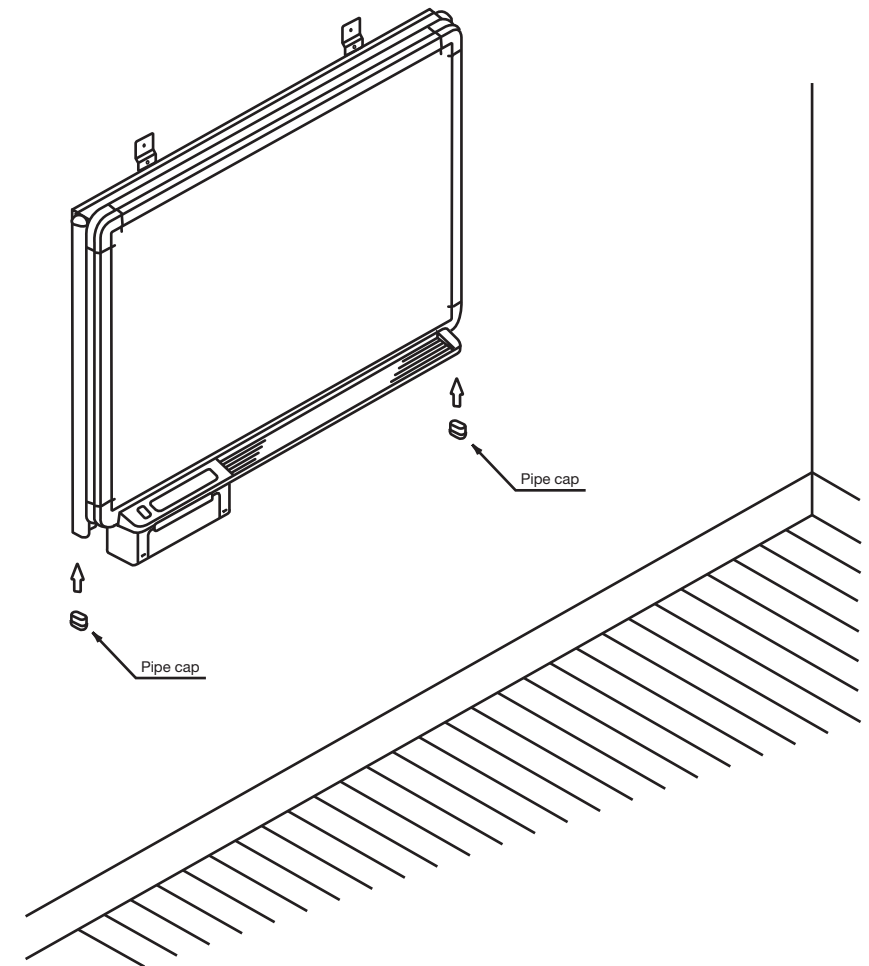

Fig. 6